

(No Model.)

G. W. CHURCH.

TOP PRESSURE FOR FEED ROLLS.

No. 359,667.

Patented Mar. 22, 1887.

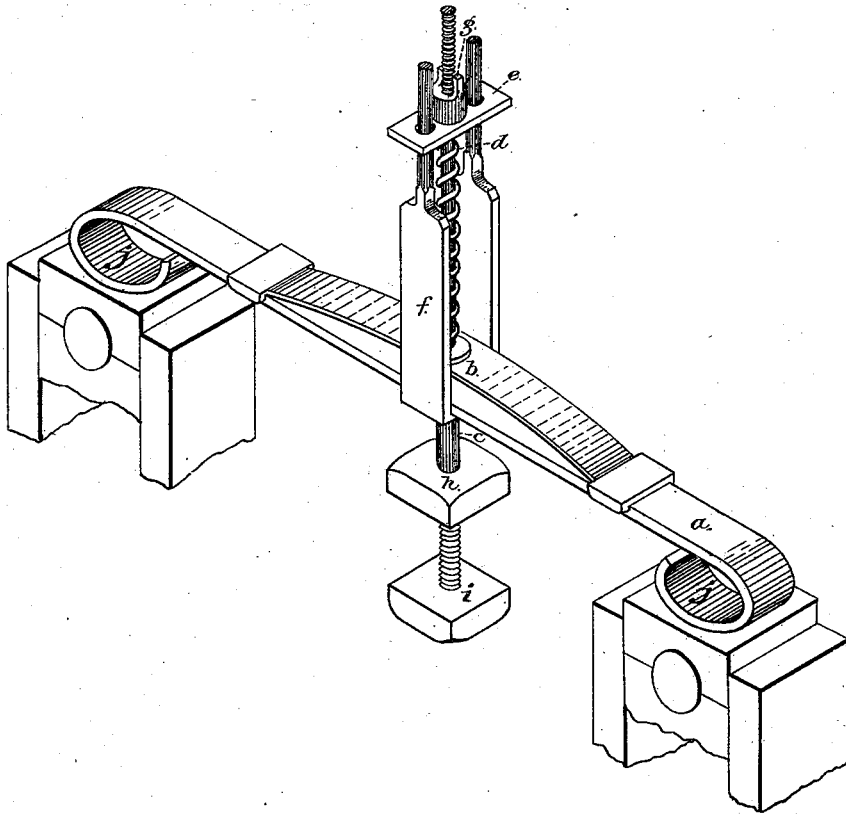

**Witnesses:**

*F. J. Steley*  
*W. J. Woodman*

**Inventor.**

*G. W. Church*

# UNITED STATES PATENT OFFICE.

GEORGE W. CHURCH, OF BOWDOINHAM, MAINE, ASSIGNOR OF ONE-HALF  
TO CHARLES W. FROST, OF SAME PLACE.

## TOP PRESSURE FOR FEED-ROLLS.

SPECIFICATION forming part of Letters Patent No. 359,667, dated March 22, 1887.

Application filed October 29, 1886. Serial No 217,499. (No model.)

*To all whom it may concern:*

Be it known that I, GEORGE W. CHURCH, of Bowdoinham, in the county of Sagadahoc and State of Maine, have invented certain new and useful Improvements in Top Pressure for Feed-Rolls; and I do hereby declare that the following is a full, clear, and exact description of the invention, which will enable others skilled in the art to which it appertains to make and use the same, reference being had to the accompanying drawing, and to letters of reference marked thereon, which forms a part of this specification.

The figure shows a view of my invention.

Same letters show like parts.

My invention relates to a top pressure for feed-rolls. It can be applied to the feed-roll of lathe-machines, paper-machines, and other machines.

The invention consists of a spring-bar, *a*, having a top elliptic spring, *b*. Down through the center of the spring-bar and elliptic extends the vertical spring-rod *c*. It is called a "spring-rod" because it has the spiral spring *d* around it. This spring rests at the lower end on the top of the elliptic *b* and at its upper end up against the yoke-strap *e*. The yoke-strap *e* fits over the two upper ends of the yoke *f*. The yoke-strap has two holes in it, through which pass the upper ends of the yoke. The yoke *f* extends down under the lower face of the spring-bar *a*.

*g* is a top tension, by which the yoke-strap is forced down on the spring to contract it, as desired. The lower end of the spring-rod *c* extends below the lower face of the spring-bar *a*, and has a screw-thread and two check-nuts, *h i*. In case of the device being used on a lathe-machine, this screw-thread and check-

nuts would serve to attach the lower end of the spring-rod to the tail-piece of such machine.

In the drawings the ends *j* of the spring-bar are shown to bear on the top of the boxes in which run the journals of the front and back feed-rolls of such lathe-machine. Now, it will be seen that as the tension is screwed downwardly the ends *j* of the spring-bar would bear on the tops of the journal-boxes, and so depress the feed-rolls, and thus make them press more firmly or with more force onto the bolt being sawed. Thus I have produced an adjustable feed-roll pressure, and one than can be easily worked. Furthermore, for example, in lathe-machines the bolts, on account of the pressure of the saws, are apt to fly back sometimes and injure the workmen.

With my improvement the bolt is held securely up to the saw and cannot fly back, and the pressure necessary to so hold the bolt is always easily regulated and applied by the top tension.

What I claim as my invention, and desire to secure by Letters Patent, is—

The combination of the spring-bar *a*, top elliptic, *b*, vertical spring-rod *c*, spiral *d*, yoke-strap *e*, yoke *f*, top tension, *g*, check-nuts *h i*, with the journal-boxes of the feed-rolls of a lathe or other machine having a top feed-roll pressure, as herein described.

In testimony that I claim the foregoing as my own I affix my signature in presence of two witnesses.

GEORGE W. CHURCH.

Witnesses:

E. W. ROBINSON,  
HENRY D. S. WOODBURY.